

High Efficiency 1.5X Fractional Charge Pump for White LED Applications

General Description

The AAT3121 is a low noise, constant frequency charge pump DC/DC converter that uses fractional (1.5X) conversion to increase efficiency in white LED applications. With input voltages ranging from 2.7V to 5.5V, the device can produce an output current of up to 120mA. A low external parts count (two 1µF flying capacitors and two small bypass capacitors at V_{IN} and OUT) makes the AAT3121 ideally suited for small battery-powered applications.

Skyworks' Simple Serial Control™ (S²Cwire™) interface is used to enable, disable, and set the LED drive current with a 32-level logarithmic scale LED brightness control. The AAT3121 has a thermal management system to protect the device in the event of a short-circuit condition on any of the output pins. Built-in soft-start circuitry prevents excessive inrush current during start-up. High switching frequency enables the use of small external capacitors. A low shutdown current feature disconnects the load from V_{IN} and reduces quiescent current to less than 1µA. The AAT3121 provides a single current source output that can be used to drive up to six LEDs at 20mA each.

The AAT3121 is available in a Pb-free TSOPJW-12 package and is rated over the -40°C to +85°C temperature range.

Features

- V_{IN} Range: 2.7V to 5.5V
- <1µA of Shutdown
- Only Four External Components
- Programmable LED Brightness
- Low Noise Constant Frequency Operation
- 33% Less Input Current Than Doubler Charge Pump
- Small Application Circuit
- Regulated Output Current
- Automatic Soft Start
- No Inductors
- TSOPJW-12 Package
- -40°C to +85°C Temperature Range

Applications

- Programmable Current Source
- White LED Backlighting

Typical Application

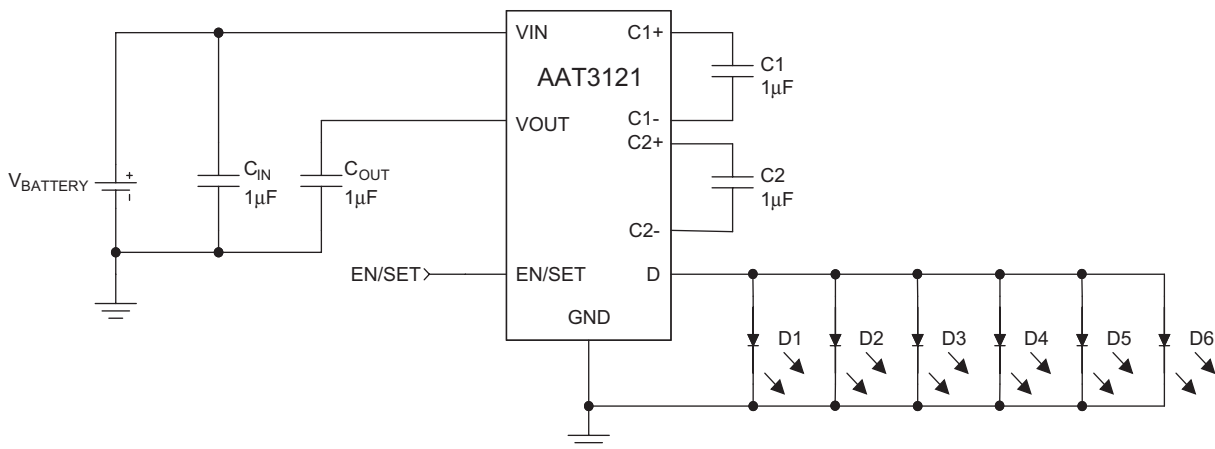

High Efficiency 1.5X Fractional Charge Pump for White LED Applications

Pin Descriptions

Pin #	Symbol	Function
1	C2+	Flying capacitor 2 positive terminal. Connect a 1 μ F capacitor between C2+ and C2-.
2	OUT	Charge pump output. Requires 1 μ F bypass capacitor to ground.
3	C1-	Flying capacitor 1 negative terminal.
4	C1+	Flying capacitor 1 positive terminal. Connect a 1 μ F capacitor between C1+ and C1-.
5, 6, 7, 8	D	Output current source with drive capability up to 120mA.
9	EN/SET	Input control pin. Serial data interface that controls the level of output current. See the Application Information section of this datasheet for more details. This pin should not be left floating.
10	IN	Input power supply. Requires 1 μ F bypass capacitor to ground.
11	GND	Ground.
12	C2-	Flying capacitor 2 negative terminal.

Pin Configuration

TSOPJW-12

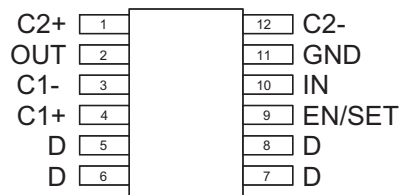

High Efficiency 1.5X Fractional Charge Pump for White LED Applications

Absolute Maximum Ratings¹

Symbol	Description	Value	Units
V_{IN}	Input Voltage	-0.3 to 6	V
V_{OUT}	Charge Pump Output	-0.3 to 6	V
$V_{EN/SET}$	EN/SET to GND Voltage	-0.3 to 6	V
$V_{EN/SET(MAX)}$	Maximum EN/SET to Input Voltage	0.3	V
I_{OUT}^2	Maximum DC Output Current	150	mA
T_J	Operating Junction Temperature Range	-40 to 150	°C

Thermal Information³

Symbol	Description	Value	Units
θ_{JA}	Thermal Resistance	160	°C/W
P_D	Power Dissipation ($T_A = 25^\circ\text{C}$) ⁴	625	mW

1. Stresses above those listed in Absolute Maximum Ratings may cause permanent damage to the device. Functional operation at conditions other than the operating conditions specified is not implied. Only one Absolute Maximum Rating should be applied at any one time.
2. Based on long-term current density limitation.
3. Mounted on an FR4 board.
4. Derate 6.25mW/°C above 25°C.

High Efficiency 1.5X Fractional Charge Pump for White LED Applications

Electrical Characteristics¹

$V_{IN} = 3.5V$, $C_{IN} = C_{OUT} = C_1 = C_2 = 1.0\mu F$; $T_A = -40^\circ C$ to $+85^\circ C$. Unless otherwise noted, typical values are $T_A = 25^\circ C$.

Symbol	Description	Conditions	Min	Typ	Max	Units
Input Power Supply						
V_{IN}	Operation Range		2.7		5.5	V
I_{CC}	Operating Current	$3.0 \leq V_{IN} \leq 5.5$, Active, No Load Current		1.8	3.5	mA
I_{SHDN}	Shutdown Current	EN = 0			1.0	μA
$I_{DX(MAX)}$	Maximum Output Current	$V_{IN} = 3.5V$; Code = 32	108	120	132	mA
Charge Pump						
T_{SS}	Soft-Start Time			200		μs
F_{CLK}	Clock Frequency			1000		kHz
η	Charge Pump Efficiency	$V_{IN} = 3.5V$, $I_{OUT} = 40mA$		93		%
EN/SET						
$V_{EN(L)}$	Enable Threshold Low	$V_{IN} = 2.7V$ to $5.5V$			0.5	V
$V_{EN(H)}$	Enable Threshold High	$V_{IN} = 2.7V$ to $5.5V$	1.4			V
T_{LO}	EN/SET Low Time		0.3		75	μs
T_{HI}	Minimum EN/SET High Time			50		ns
T_{OFF}	EN/SET Off Timeout				500	μs
Input Current	EN/SET Input Leakage		-1.0		1.0	μA

1. The AAT3121 is guaranteed to meet performance specifications over the $-40^\circ C$ to $+85^\circ C$ operating temperature range and is assured by design, characterization, and correlation with statistical process controls.

High Efficiency 1.5X Fractional Charge Pump for White LED Applications

Typical Characteristics

Unless otherwise noted, $V_{IN} = 3.5V$, $C_{IN} = C_{OUT} = C_1 = C_2 = 1\mu F$, $T_A = 25^\circ C$.

I_{DIODE} vs. V_{IN}
(4x20mA)

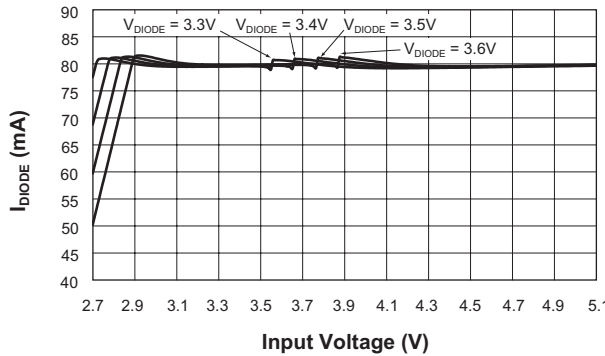

V_{IH} and V_{IL} vs. V_{IN}

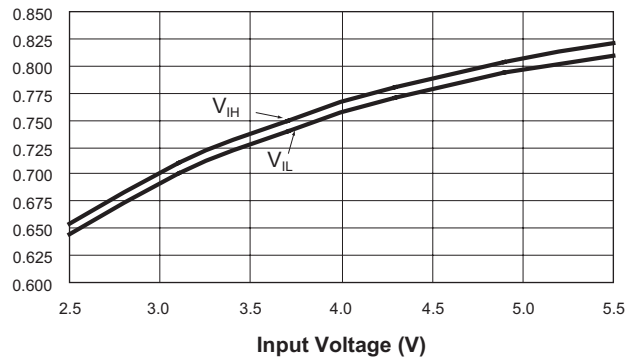

Turn-On to Full-Scale Charge Pump

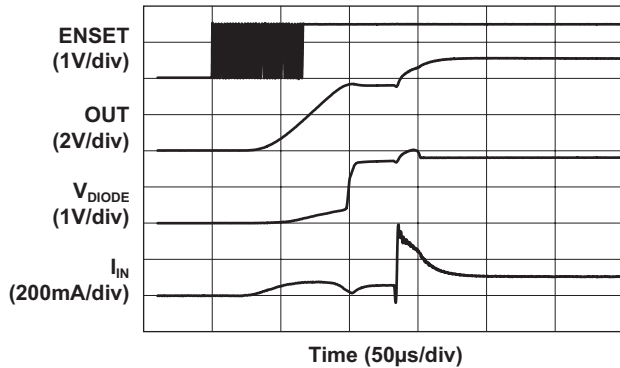

Turn-On to Full-Scale Load Switch

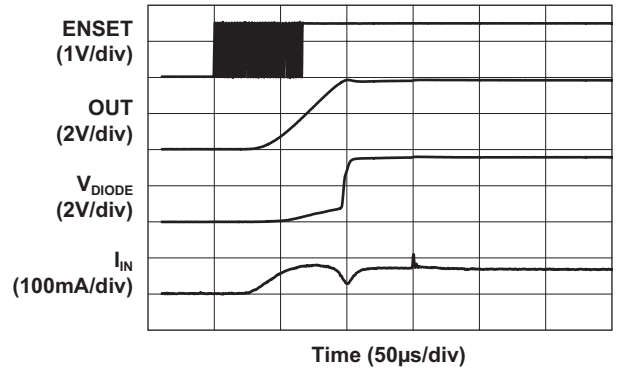

Turn-Off

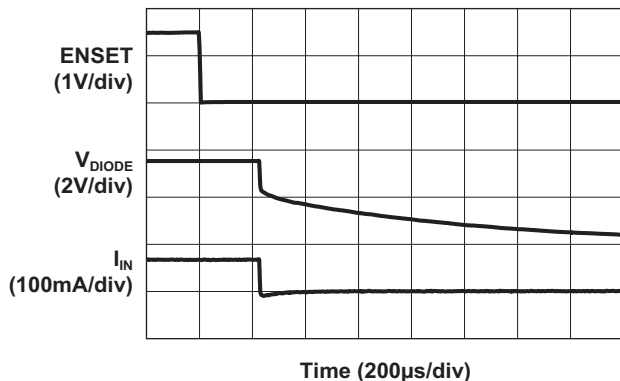

80mA Load Characteristics

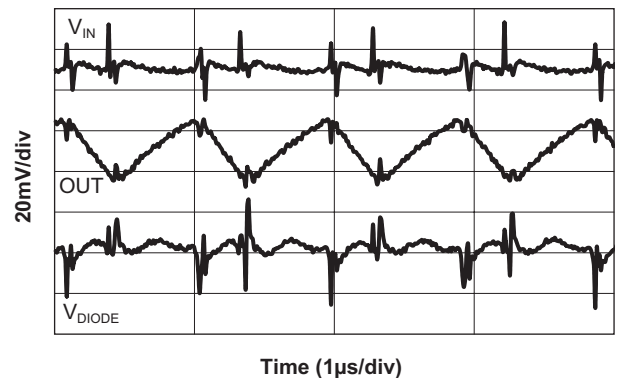

High Efficiency 1.5X Fractional Charge Pump for White LED Applications

Functional Block Diagram

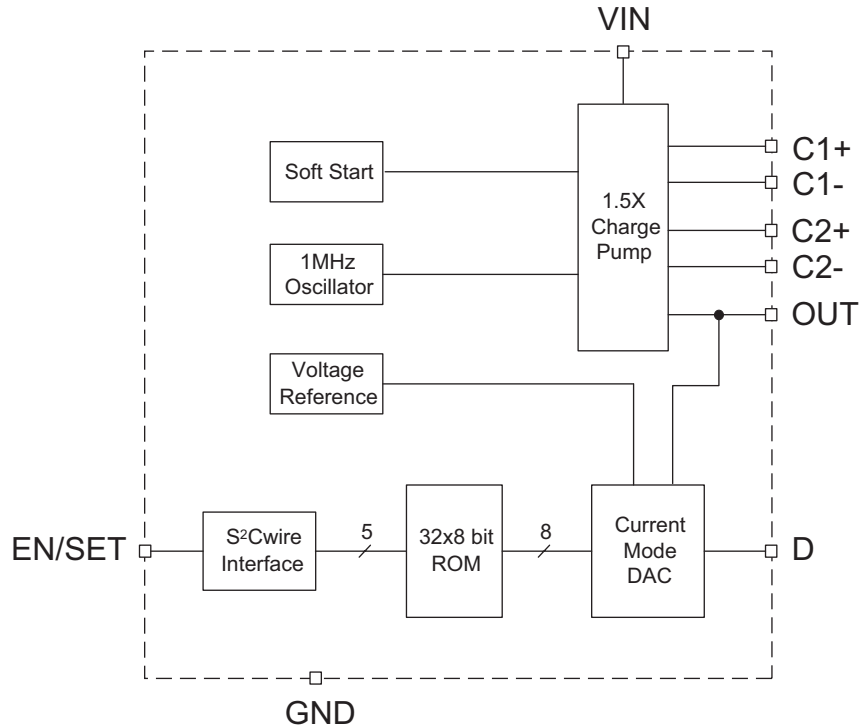

Functional Description

The AAT3121 is a high efficiency 1.5X fractional charge pump device intended for white LED backlight applications. The AAT3121 requires only four external components: two 1 μ F ceramic capacitors for the charge pump flying capacitors (C1 and C2), one 1 μ F ceramic capacitor for C_{IN}, and one 0.33 μ F to 1 μ F ceramic capacitor for C_{OUT}. The charge pump output is converted into a constant current output capable of driving up to six individual LEDs with a maximum of 120mA. The current source output magnitude is controlled by the EN/SET serial data interface. The interface records rising edges of the EN/SET pin and decodes them into 32 individual current level set-

tings each 1dB apart (see Figure 1). Code 32 is full scale, and Code 1 is full scale attenuated by 31dB. The modulo 32 interface wraps states back to State 1 after the 32nd clock. With each EN/SET pulse, the output current increases by 1dB. To decrease the output current by 1dB, 31 EN/SET clock pulses are required. The counter can be clocked at speeds up to 1MHz, so intermediate states are not visible. The first rising edge of EN/SET enables the IC and initially sets the output LED current to -31dB, the lowest setting: 3.3mA. Once the final clock cycle is input for the desired brightness level, the EN/SET pin is held high to maintain the device output current at the programmed level. The device is disabled 500 μ s after the EN/SET pin transitions to a logic low state.

High Efficiency 1.5X Fractional Charge Pump for White LED Applications

Applications Information

Current Level Settings

LED current level is set via the serial interface according to a logarithmic scale where each code is 1dB greater than the previous code. In this manner, the LED brightness appears linear with each increasing code. Table 1 depicts the relationship between each rising edge of the EN/SET and the output current in mA.

Code	I _{OUT} (mA)	Code	I _{OUT} (mA)
1	3.294	17	21.176
2	3.765	18	24.000
3	4.235	19	26.824
4	4.706	20	30.118
5	5.176	21	33.882
6	6.118	22	38.118
7	6.588	23	42.353
8	7.529	24	47.529
9	8.471	25	53.647
10	9.412	26	60.235
11	10.824	27	67.294
12	11.765	28	75.765
13	13.647	29	84.706
14	15.059	30	95.059
15	16.941	31	106.824
16	18.824	32	120.000

Table 1: Current Level Settings.

EN/SET Serial Interface

The current source output magnitude is controlled by the EN/SET serial data interface. The interface records rising edges of the EN/SET pin and decodes them into 32 individual current level settings each 1dB apart. Code 32 is full scale, and Code 1 is full scale attenuated by 31dB. The modulo 32 interface wraps states back to State 1 after the 32nd clock, so 1dB of attenuation is achieved by clocking the EN/SET pin 31 times. The counter can be clocked at speeds up to 1MHz, so intermediate states are not visible. The first rising edge of EN/SET enables the IC and initially sets the output LED current to -31dB, the lowest setting: 3.3mA. Once the final clock cycle is input for the desired brightness level, the EN/SET pin is held high to maintain the device output current at the programmed level. The device is disabled 500µs after the EN/SET pin transitions to a logic low state.

The EN/SET timing is designed to accommodate a wide range of data rates. After the first rising edge of EN/SET, the charge pump is enabled and reaches full capacity after the soft-start time (T_{SS}). During the soft-start time, multiple clock pulses may be entered on the EN/SET pin to set the final output current level with a single burst of clocks. Alternatively, the EN/SET clock pulses may be entered one at a time to gradually increase the LED brightness over any desired time period. A constant current is sourced as long as EN/SET remains in a logic high state. The current source outputs are switched off after EN/SET has remained in a low state for at least the T_{OFF} timeout period.

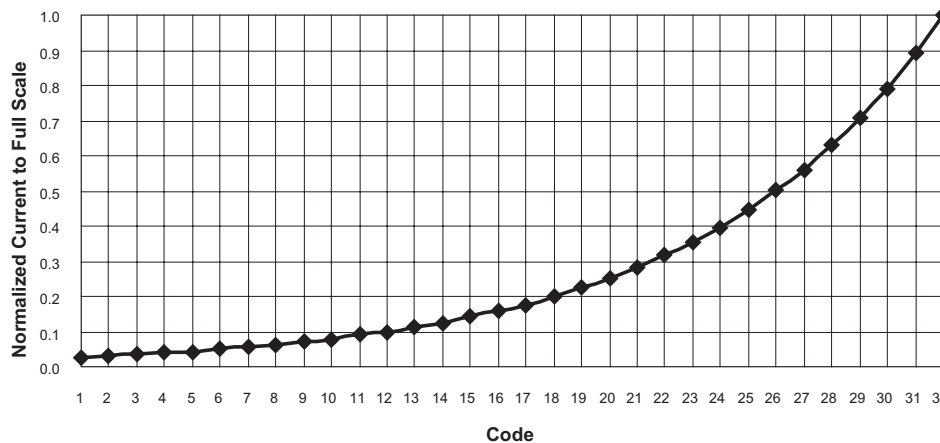
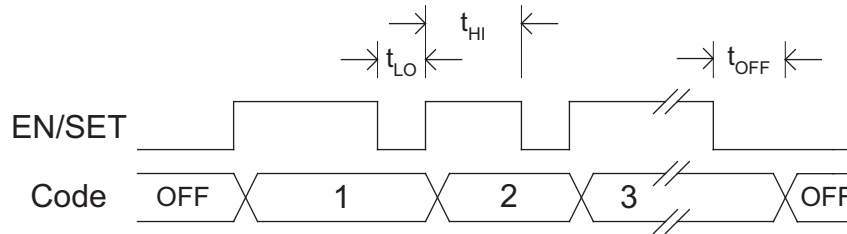

Figure 1: Normalized Current Level Settings.

High Efficiency 1.5X Fractional Charge Pump for White LED Applications

EN/SET Timing Diagram



LED Selection

The AAT3121 is specifically intended for driving white LEDs. However, the device design will allow the AAT3121 to drive most types of LEDs with forward voltage specifications ranging from 2.0V to 4.3V. LED applications may include main and sub-LCD display backlighting, camera photo-flash applications, color (RGB) LEDs, infrared (IR) diodes for remotes, and other loads benefiting from a controlled output current generated from a varying input voltage.

Device Switching Noise Performance

The AAT3121 operates at a fixed frequency of approximately 1MHz to control noise and limit harmonics that can interfere with the RF operation of cellular telephone handsets or other communication devices. Back-injected noise appearing on the input pin of the charge pump is 20mV peak-to-peak, typically ten times less than inductor-based DC/DC boost converter white LED backlight solutions. The AAT3121 soft-start feature prevents noise transient effects associated with inrush currents during start-up of the charge pump circuit.

Power Efficiency and Device Evaluation

Due to the unique charge pump circuit architecture and design of the AAT3121, it is very difficult to measure efficiency in terms of a percent value comparing input power over output power.

Since the AAT3121 output is purely constant current source, it is difficult to measure the output voltage to derive an overall output power measurement. For any given application, white LED forward voltage levels can differ, yet the output drive current will be maintained as a constant.

This makes quantifying output power a difficult task when taken in the context of comparing to other white LED driver circuit topologies. A better way to quantify total device efficiency is to observe the total input power to the device for a given LED current drive level. The best white LED driver for a given application should be based on trade-offs of size, external components count, reliability, operating range, and total energy usage...*not just % efficiency.*

Charge Pump Efficiency

The AAT3121 is a fractional charge pump. The efficiency (η) can be simply defined as a linear voltage regulator with an effective output voltage that is equal to one and one half times the input voltage. Efficiency (η) for an ideal 1.5X charge pump can typically be expressed as the output power divided by the input power.

$$\eta = \frac{P_{OUT}}{P_{IN}}$$

In addition, with an ideal 1.5X charge pump, the output current may be expressed as 2/3 of the input current. The expression to define the ideal efficiency (η) can be rewritten as:

$$\eta = \frac{P_{OUT}}{P_{IN}} = \frac{V_{OUT} \cdot I_{OUT}}{V_{IN} \cdot 1.5I_{OUT}} = \frac{V_{OUT}}{1.5V_{IN}}$$

-or-

$$\eta(\%) = 100 \left(\frac{V_{OUT}}{1.5V_{IN}} \right)$$

For a charge pump with an output of 5V and a nominal input of 3.5V, the theoretical efficiency is 95%. Due to internal switching losses and IC quiescent current consumption, the actual efficiency can be measured at 93%.

High Efficiency 1.5X Fractional Charge Pump for White LED Applications

These figures are in close agreement for output load conditions from 3.0mA to 120mA. Efficiency will decrease as load current drops below 0.05mA or when level of V_{IN} approaches V_{OUT} . Refer to the Typical Characteristics section of this datasheet for measured plots of efficiency versus input voltage and output load current for the given charge pump output voltage options.

Capacitor Selection

Careful selection of the four external capacitors C_{IN} , C_1 , C_2 , and C_{OUT} is important because they will affect turn-on time, output ripple, and transient performance. Optimum performance will be obtained when low equivalent series resistance (ESR) ceramic capacitors are used. In general, low ESR may be defined as less than 100m Ω . A value of 1 μ F for all four capacitors is a good starting point when choosing capacitors. If the LED current sources are only programmed for light current levels, then the capacitor size may be decreased.

Capacitor Characteristics

Ceramic composition capacitors are highly recommended over all other types of capacitors for use with AAT3121 products. Ceramic capacitors offer many advantages over their tantalum and aluminum electrolytic counterparts. A ceramic capacitor typically has very low ESR, is lowest cost, has a smaller PCB footprint, and is non-polarized. Low ESR ceramic capacitors help maximize charge pump transient response. Since ceramic capacitors are non-polarized, they are not prone to incorrect connection damage.

Equivalent Series Resistance: ESR is an important characteristic to consider when selecting a capacitor. ESR is a resistance internal to a capacitor that is caused by the leads, internal connections, size or area, material composition, and ambient temperature. Capacitor ESR is typically measured in milliohms for ceramic capacitors and can range to more than several ohms for tantalum or aluminum electrolytic capacitors.

Ceramic Capacitor Materials: Ceramic capacitors less than 0.1 μ F are typically made from NPO or COG materials. NPO and COG materials typically have tight tolerance and are stable over temperature. Large capacitor values are typically composed of X7R, X5R, Z5U, or Y5V dielectric materials. Large ceramic capacitors, typically greater than 2.2 μ F are often available in low-cost Y5V and Z5U dielectrics, but large capacitors are not required in the AAT3121 application.

Capacitor area is another contributor to ESR. Capacitors that are physically large will have a lower ESR when compared to an equivalent material smaller capacitor. These larger devices can improve circuit transient response when compared to an equal value capacitor in a smaller package size.

Thermal Protection

The AAT3121 has a thermal protection circuit that will shut down the charge pump and current outputs if the die temperature rises above the thermal limit due to short-circuit conditions.

High Efficiency 1.5X Fractional Charge Pump for White LED Applications

Ordering Information

Package	Marking ¹	Part Number (Tape and Reel) ²
TSOPJW-12	JQXY	AAT3121ITP-T1



Skyworks Green™ products are compliant with all applicable legislation and are halogen-free. For additional information, refer to *Skyworks Definition of Green™*, document number SQ04-0074.

Package Information

TSOPJW-12

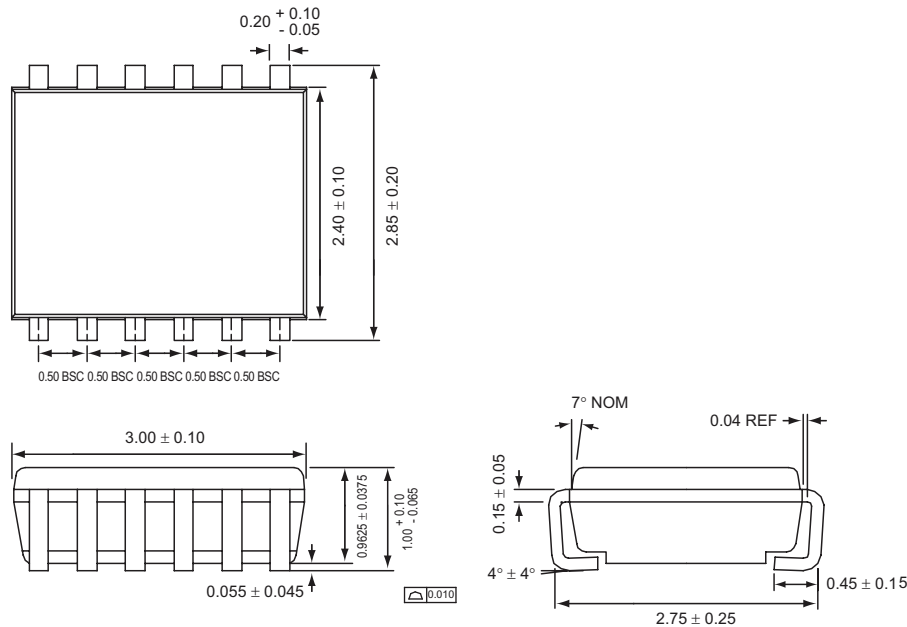

All dimensions in millimeters.

1. XYZ = assembly and date code.
2. Sample stock is generally held on part numbers listed in BOLD.

Copyright © 2012 Skyworks Solutions, Inc. All Rights Reserved.

Information in this document is provided in connection with Skyworks Solutions, Inc. ("Skyworks") products or services. These materials, including the information contained herein, are provided by Skyworks as a service to its customers and may be used for informational purposes only by the customer. Skyworks assumes no responsibility for errors or omissions in these materials or the information contained herein. Skyworks may change its documentation, products, services, specifications or product descriptions at any time, without notice. Skyworks makes no commitment to update the materials or information and shall have no responsibility whatsoever for conflicts, incompatibilities, or other difficulties arising from any future changes.

No license, whether express, implied, by estoppel or otherwise, is granted to any intellectual property rights by this document. Skyworks assumes no liability for any materials, products or information provided hereunder, including the sale, distribution, reproduction or use of Skyworks products, information or materials, except as may be provided in Skyworks Terms and Conditions of Sale.

THE MATERIALS, PRODUCTS AND INFORMATION ARE PROVIDED "AS IS" WITHOUT WARRANTY OF ANY KIND, WHETHER EXPRESS, IMPLIED, STATUTORY, OR OTHERWISE, INCLUDING FITNESS FOR A PARTICULAR PURPOSE OR USE, MERCHANTABILITY, PERFORMANCE, QUALITY OR NON-INFRINGEMENT OF ANY INTELLECTUAL PROPERTY RIGHT; ALL SUCH WARRANTIES ARE HEREBY EXPRESSLY DISCLAIMED. SKYWORKS DOES NOT WARRANT THE ACCURACY OR COMPLETENESS OF THE INFORMATION, TEXT, GRAPHICS OR OTHER ITEMS CONTAINED WITHIN THESE MATERIALS. SKYWORKS SHALL NOT BE LIABLE FOR ANY DAMAGES, INCLUDING BUT NOT LIMITED TO ANY SPECIAL, INDIRECT, INCIDENTAL, STATUTORY, OR CONSEQUENTIAL DAMAGES, INCLUDING WITHOUT LIMITATION, LOST REVENUES OR LOST PROFITS THAT MAY RESULT FROM THE USE OF THE MATERIALS OR INFORMATION, WHETHER OR NOT THE RECIPIENT OF MATERIALS HAS BEEN ADVISED OF THE POSSIBILITY OF SUCH DAMAGE.

Skyworks products are not intended for use in medical, lifesaving or life-sustaining applications, or other equipment in which the failure of the Skyworks products could lead to personal injury, death, physical or environmental damage. Skyworks customers using or selling Skyworks products for use in such applications do so at their own risk and agree to fully indemnify Skyworks for any damages resulting from such improper use or sale.

Customers are responsible for their products and applications using Skyworks products, which may deviate from published specifications as a result of design defects, errors, or operation of products outside of published parameters or design specifications. Customers should include design and operating safeguards to minimize these and other risks. Skyworks assumes no liability for applications assistance, customer product design, or damage to any equipment resulting from the use of Skyworks products outside of stated published specifications or parameters.

Skyworks, the Skyworks symbol, and "Breakthrough Simplicity" are trademarks or registered trademarks of Skyworks Solutions, Inc., in the United States and other countries. Third-party brands and names are for identification purposes only, and are the property of their respective owners. Additional information, including relevant terms and conditions, posted at www.skyworksinc.com, are incorporated by reference.